

# AC7063M Datasheet

**Zhuhai Jieli Technology Co.,LTD**

**Version: 1.5**

**Date: 2023.11.03**



(low power available,can be multiplexed to any I/O)

#### **PMU**

- Built-in lithium battery charging manager,up to 300mA charging current
- Built-in LDO
- Minimum 3uA current consumption in the soft-off mode
- VPWR range : 4.5V to 5.5V

- VBAT range : 2.7V to 4.5V
- IOVDD range : 2.2V to 3.4V

#### **Packages**

- QFN20 (3mm\*3mm)

#### **Temperature**

- Operating temperature: -40°C to +85°C
- Storage temperature: -65°C to +150°C

#### **Applications**

- Wireless microphone

JIELI TECHNOLOGY

## 1. Block Diagram

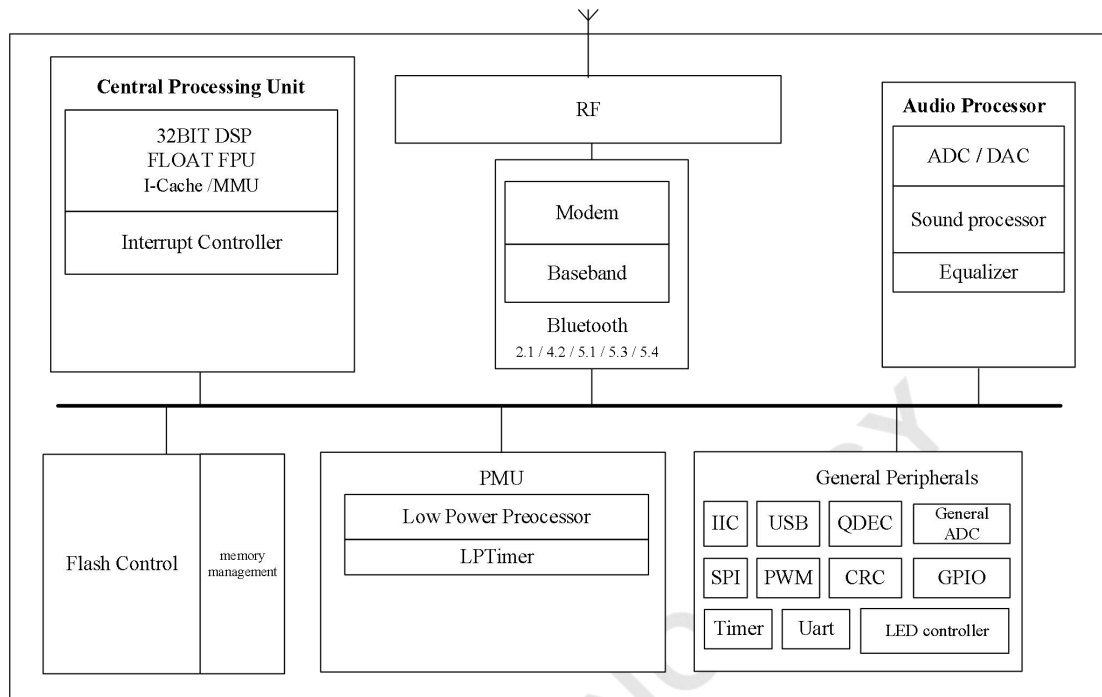

**Figure 1-1 AC7063M Block Diagram**

## 2. Pin Definition

### 2.1. Pin Assignment

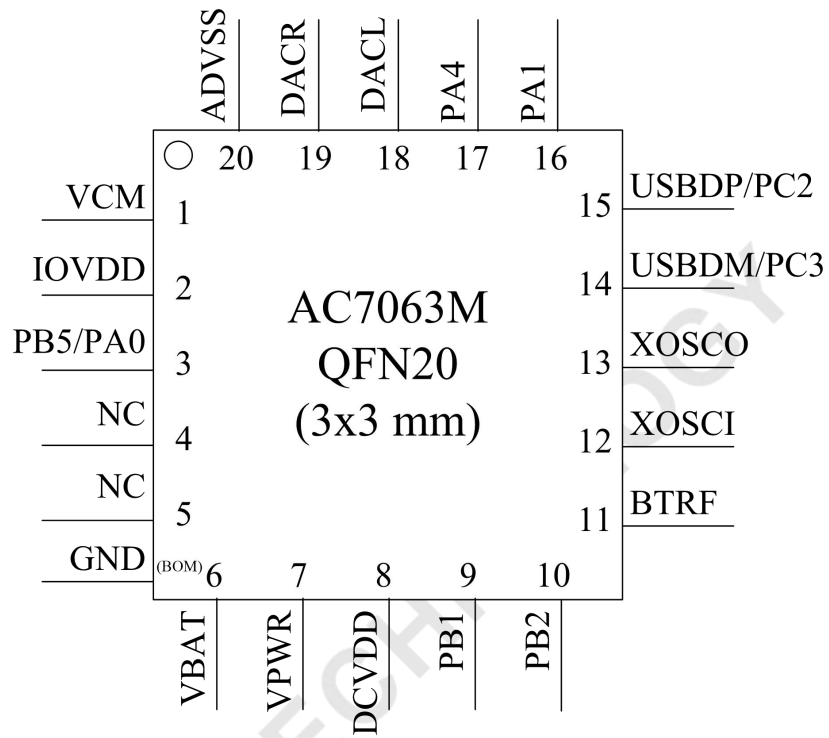

Figure 2-1 AC7063M Package Diagram

## 2.2. Pin Description

**Table 2-2 AC7063M Pin Description**

Pin No.	Pin name	Type	Function	Other function
1	VCM	P		
2	IOVDD	PO		
3	PB5	I/O	GPIO	ADC Input Channel 5 SD power gate SPI1 Data1 In(C)/SPI0 Data1 In(B)
	PA0	I/O	GPIO	ADC Input Channel 0; MIC0 Bias Output(Built-in resistor)/MICLDO Clock Out0 WiFi bluetooth co-existence WLC_EXT_ACT
4	NC		(No Connection)	
5	NC		(No Connection)	
6	VBAT	PI		Battery Input
7	VPWR	PI (I/O)	GPIO (High Voltage Resistant)	Charge Power Input Uart0 Data Out(C)/Uart0 Data In(C) Timer3 PWM Output Timer1 Capture
8	DCVDD	P		
9	PB1	I/O	GPIO (pull up)	Hold down 0 to reset ADC Input channel 0 Uart0 Data In(B) Timer2 Clock In Uart0 Data In
10	PB2	I/O	GPIO	ADC Input Channel 6 32k Crystal Oscillator input Timer0 Capture
11	BTRF	RF		Bluetooth RF antenna
12	XOSCI	I		System Crystal Oscillator Input
13	XOSCO	O		System Crystal Oscillator Output
14	USBDM	I/O	GPIO (pull down)	USB Negative Data ADC Input Channel 14 SPI1 Data0 Out(D) IIC Serial Data(A)
	PC3	I/O	GPIO	ADC Input Channel 10 SPI1 Data1 In(D) Uart0 Data Out(D)/Uart0 Data In(D) Timer2 Capture Clock Out2

15	USBDP	I/O	GPIO (pull down)	USB Positive Data ADC Input Channel 13 SPI1 Clock(D) IIC Serial Clock(A)
	PC2	I/O	GPIO	ADC Input Channel 15 SPI1 Data2(B/C/D) Clock Out1 External LNA enable
16	PA1	I/O	GPIO	ADC Input Channel 1 MIC input
17	PA4	I/O	GPIO	ADC Input Channel 3 AUX2 input SPI1 Data In(A) SPI0 Data Out WiFi bluetooth co-existence WLC_EXT_ACTIVE
18	DACL	AO	Analog Output	Left channel audio output
19	DACR	AO	Analog Output	Right channel audio output
20	ADVSS	G		Audio Ground
BOM	GND	G		Ground
Uart1、SD-card function can be remapped to any I/O				

Pin Type	Description	Pin Type	Description
P	Power	I/O	Input or Output
PO	Power Output	I	Input
PI	Power Input	O	Output
G	Ground	RF	RF antenna
AO	Analog Output		

### 3. Electrical Characteristics

#### 3.1. Absolute Maximum Ratings

Table 3-1

Symbol	Parameter	Min	Max	Unit
T <sub>opt</sub>	Operating temperature	-40	+85	°C
T <sub>stg</sub>	Storage temperature	-65	+150	°C
V <sub>BAT</sub>	Supply Voltage	-0.3	4.5	V
V <sub>PWR</sub>	Charger Voltage	-0.3	6	V
V <sub>IOVDD</sub>	Voltage applied at IOVDD	-0.3	3.6	V
V <sub>GPIO</sub>	Voltage applied to GPIO	-0.3	3.6	V
V <sub>HVTIO</sub>	Voltage applied to High Voltage Resistant IO	-0.3	+5.5	V

Note : The chip can be damaged by any stress in excess of the absolute maximum ratings listed below

#### 3.2. PMU Characteristics

Table 3-2

Symbol	Parameter	Min	Typ	Max	Unit	Test Conditions
V <sub>BAT</sub>	Voltage Input	2.7	3.7	4.5	V	
V <sub>PWR</sub>	Charger supply Voltage	4.5	5.0	5.5	V	
Operating mode						
IOVDD	Voltage output		3.2		V	V <sub>BAT</sub> = 4.2V, 10mA loading
	Loading current			300	mA	IOVDD=3.2V@V <sub>BAT</sub> = 3.7V
DCVDD	Voltage output		1.4		V	IOVDD=3.2V, 10mA loading
	Loading current			150	mA	DCVDD=1.4V@IOVDD=3.2v on LDO mode
Low Power mode						
IOVDD	Loading current			20	mA	IOVDD=3.2V@V <sub>BAT</sub> = 3.7V



### 3.3. Battery Charge

**Table 3-3**

Symbol	Parameter	Min	Typ	Max	Unit	Test Conditions
VPWR	Charge Input Voltage	4.5	5	5.5	V	
V <sub>bat float</sub>	Charge Voltage	4.15	4.2	4.25	V	VPWR>4.5V
		4.30	4.35	4.40	V	VPWR>4.65V
I <sub>bat</sub>	Charge Current	15		350	mA	Charge current at fast charge mode VBAT=4.0V@VPWR=5.0V
I <sub>end</sub>	End Of Charge Current	1.5		35	mA	End of charge current
V <sub>Trickl</sub>	Trickle Charge Voltage		3.0		V	VPWR>4.5V

### 3.4. IO Input/Output Electrical Logical Characteristics

**Table 3-4**

GPIO input characteristics						
Symbol	Parameter	Min	Typ	Max	Unit	Test Conditions
V <sub>IL</sub>	Low-Level Input Voltage	-0.3		1.4	V	IOVDD = 3.2V
V <sub>IH</sub>	High-Level Input Voltage	1.8		3.6	V	IOVDD = 3.2V
High Voltage Resistant IO input characteristics						
Symbol	Parameter	Min	Typ	Max	Unit	Test Conditions
V <sub>IL</sub>	Low-Level Input Voltage	-0.3		1.4	V	IOVDD = 3.2V
V <sub>IH</sub>	High-Level Input Voltage	1.8		5.5	V	IOVDD = 3.2V
GPIO & High Voltage Resistant IO output characteristics						
Symbol	Parameter	GPIO		Typ	Unit	Test Conditions
V <sub>OL</sub>	0.1* IOVDD Drive current	Except VPWR		HD=0 : -1.8 HD=1 : -6 HD=2 : -20 HD=3 : -24	mA	IOVDD = 3.2V
		VPWR		-8		
V <sub>OH</sub>	0.9* IOVDD Drive current	Except VPWR		HD=0 : 1.8 HD=1 : 6 HD=2 : 20 HD=3 : 45	mA	IOVDD = 3.2V
		VPWR		8		

### 3.5. Internal Resistor Characteristics

Table 3-5

Port	Internal Pull-Up Resistor	Internal Pull-Down Resistor	Comment
PA0,PA1,PA4 PB2 PC2,PC3	10K	10K	1、PB1 default pull up 200KΩ 2、USBDM & USBDP default pull Down 15KΩ 3、internal pull-up / pull-down resistance   accuracy ±20%
PB1,PB5 PP0(VPWR)	200K	10K	
USBDP	1.5K	15K	
USBDM	180K	15K	

### 3.6. Audio DAC Characteristics

Table 3-6

Parameter	MODE	Min	Typ	Max	Unit	Test Conditions
Frequency Response		20		20k	Hz	
Output Swing	Single-ended		0.8		Vrms	Fin=1kHz/0dB
	Differential		1.7		Vrms	Fs=44.1kHz
THD+N	Single-ended		-80		dB	B/W=20Hz~20kHz
	Differential		-85		dB	A-Weighted Filter
S/N	Single-ended		100		dB	10k ohm loading
	Differential		103		dB	
Noise Floor	Single-ended		8		uVrms	A-Weighted Filter
	Differential		12		uVrms	
Crosstalk	Single-ended		-110		dB	Fin=1kHz/0dB
Output Power	32ohm	Single-ended	20		mW	Fin=1kHz Fs=44.1kHz THD+N < 0.1%
		Differential	52		mW	
	16ohm	Single-ended	30		mW	
		Differential	75		mW	

### 3.7. Audio ADC Characteristics

**Table 3-7**

Parameter		Min	Typ	Max	Unit	Test Conditions
Maximum Input Level	Differential		1.8		Vrms	Gain Level = 0 Fin = 1kHz Fs = 44.1kHz THD+N < 0.1%
	Single-ended		0.9		Vrms	
SNR	Differential		98		dB	Gain Level = 0 Fs = 44.1kHz Fin = 1kHz, Maximum Input B/W = 20Hz~20kHz A-Weighted Filter
	Single-ended		97		dB	
THD+N	Differential		-80		dB	
	Single-ended		-80		dB	
SNR (AD to DA)	Differential to Single-ended		96		dB	
	Differential to Differential		97		dB	
	Single-ended to Single-ended		94		dB	
	Single-ended to Differential		95		dB	
THD+N (AD to DA)	Differential to Single-ended		-80		dB	
	Differential to Differential		-80		dB	
	Single-ended to Single-ended		-80		dB	
	Single-ended to Differential		-80		dB	

### 3.8. BT Characteristics

#### 3.8.1. Transmitter

**Basic Data Rate**
**Table 3-8-1-1**

Parameter		Min	Typ	Max	Unit	Test Conditions
RF Transmit Power, DH5			7.5	10	dBm	25°C Power Supply
RF Power Control Range, DH1			20		dB	
20dB Bandwidth, DH5			950		KHz	
Adjacent Channel	+2MHz		-40		dBm	VBAT=3.7V 2441MHz
	-2MHz		-40		dBm	
Transmit Power, DH1	+3MHz		-45		dBm	4 Layer Board
	-3MHz		-45		dBm	

**Enhanced Data Rate**
**Table 3-8-1-2**

Parameter		Min	Typ	Max	Unit	Test Conditions
Relative Power			-3		dB	25°C Power Supply
$\pi/4$ DQPSK Modulation Accuracy	DEVM RMS		10		%	
	DEVM 99%		15		%	
	DEVM Peak		20		%	
In-band spurious Emissions	+2MHz		-35		dBm	2441MHz
	-2MHz		-35		dBm	2DH5
	+3MHz		-40		dBm	4 Layer Board
	-3MHz		-40		dBm	

### 3.8.2. Receiver

**Basic Data Rate** **Table 3-8-2-1**

Parameter		Min	Typ	Max	Unit	Test Conditions
Sensitivity			-92		dBm	25°C
Co-channel Interference Rejection			10		dB	
Adjacent Channel Interference Rejection	+1MHz		-30		dB	Power Supply
	-1MHz		-30		dB	VBAT=3.7V
	+2MHz		-40		dB	2441MHz
	-2MHz		-40		dB	DH1
	+3MHz		-40		dB	4 Layer Board
	-3MHz		-		dB	

**Enhanced Data Rate** **Table 3-8-2-2**

Parameter		Min	Typ	Max	Unit	Test Conditions
Sensitivity			-92		dBm	25°C
Co-channel Interference Rejection			10		dB	
Adjacent Channel Interference Rejection	+1MHz		-30		dB	Power Supply
	-1MHz		-30		dB	VBAT=3.7V
	+2MHz		-40		dB	2441MHz
	-2MHz		-40		dB	2DH5
	+3MHz		-40		dB	4 Layer Board
	-3MHz		-		dB	

**3.8.3. BLE**
**1M Data Rate**
**Table 3-8-3-1**

Parameter		Min	Typ	Max	Unit	Test Conditions
Sensitivity			-95		dBm	25°C Power Supply VBAT=3.7V 2440MHz 4 Layer Board
RF Transmit Power			7.5		dB	
In-band spurious Emissions	+2MHz		-40		dBm	
	-2MHz		-40		dBm	
	+3MHz		-40		dBm	
	-3MHz		-40		dBm	
Modulation Characteristics	$\Delta f1$ avg		250		KHz	
	$\Delta f2$ 99%		210		KHz	
	$\Delta f1$ avg/ $\Delta f2$ av		0.9			
Carrier Frequency Offset		-15		+15	KHz	
Frequency Drift		-25		+25	KHz	
Frequency Drift Rate		-5		+5	KHz/50us	

**2M Data Rate**
**Table 3-8-3-2**

Parameter		Min	Typ	Max	Unit	Test Conditions
Sensitivity			-92		dBm	25°C Power Supply VBAT=3.7V 2440MHz 4 Layer Board
RF Transmit Power			7.5		dB	
In-band spurious Emissions	+4MHz		-40		dBm	
	-4MHz		-40		dBm	
	+5MHz		-40		dBm	
	-5MHz		-40		dBm	
	+6MHz		-50		dBm	
	-6MHz		-35		dBm	
Modulation Characteristics	$\Delta f1$ avg		500		KHz	
	$\Delta f2$ 99%		430		KHz	
	$\Delta f1$ avg/ $\Delta f2$ av		0.9			
Carrier Frequency Offset		-15		+15	KHz	
Frequency Drift		-25		+25	KHz	
Frequency Drift Rate		-5		+5	KHz/50us	

### 3.9. ESD Protection

**Table 3-10**

Parameter	Typ.	Test pin	Reference standard
Human Body Mode	±4KV	All pins	JEDEC EIA/JESD22-A114
Machine Mode	±200V	All pins	JEDEC EIA/JESD22-A115
Charge Device Model	±1KV	All pins	JEDEC EIA/JESD22-C101F
Latch up	±200mA	All GPIO pins	JEDEC STANDARD NO.78E
	1.5xVopmax	All power pins	

Note : 1.5xVopmax = 1.5 times maximum operating voltage.

## 4. Package Information

### 4.1 QFN20\_3mm x 3mm

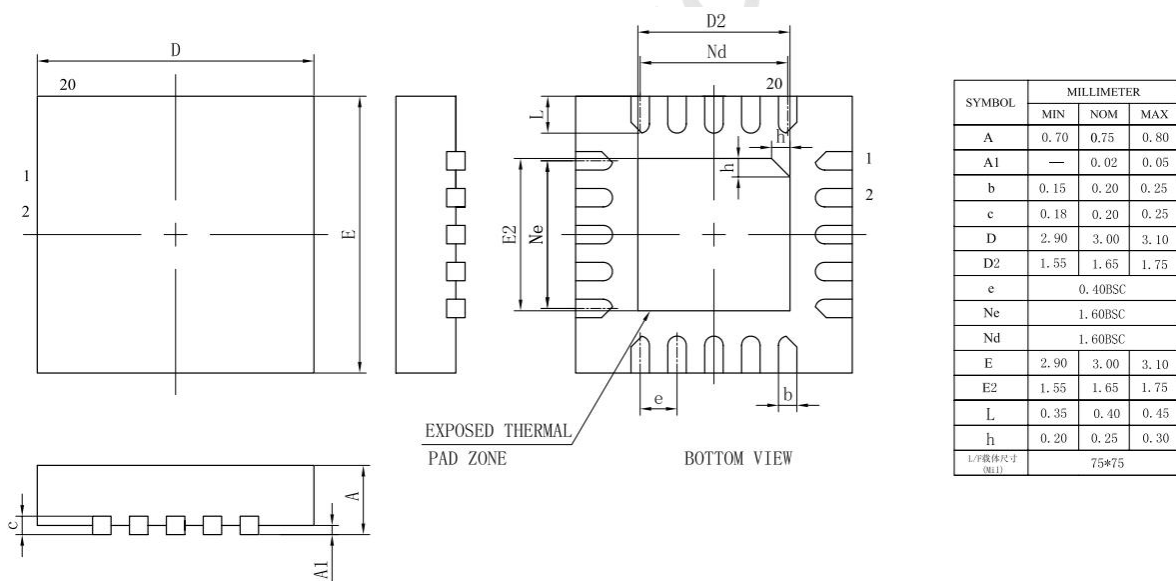

**Figure 4-1 AC7063M Package**

## 5. IC Marking Information

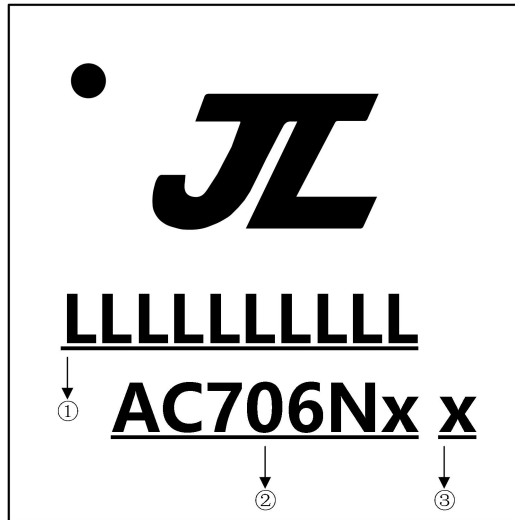

- ① LLLLLLLLLL: Production Batch
- ② AC706Nx: Chip Model
- ③ x: Built-in flash size
  - 0: No Flash Memory
  - 2: 2Mbit Flash
  - 4: 4Mbit Flash
  - 8: 8Mbit Flash
  - 6: 16Mbit Flash
  - 3: 32Mbit Flash



## 6. Solder-Reflow Condition

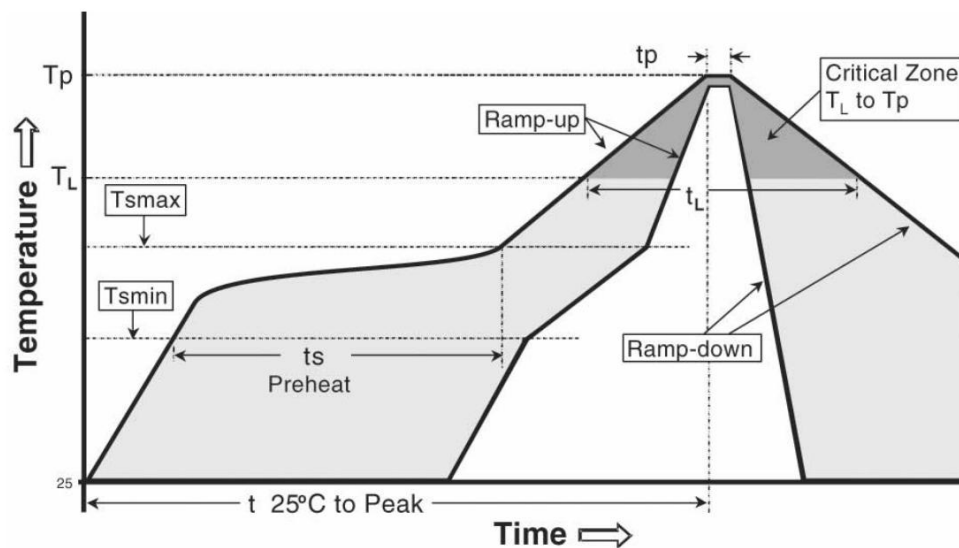

Figure 6-1 Classification Reflow Profile

### Classification Profiles

Table 6-1

Profile Feature		Sn-Pb Eutectic Assembly	Pb-Free Assembly
Preheat /Soak	Temperature Min ( $T_{smin}$ )	100°C	150°C
	Temperature Max ( $T_{smax}$ )	150°C	200°C
	Time ( $t_s$ ) from ( $T_{smin}$ to $T_{smax}$ )	60-120 seconds	60-180 seconds
Average ramp-up rate ( $T_{smax}$ to $T_p$ )		3°C/second max	3°C/second max
Liquidous temperature ( $T_L$ )		183°C	217°C
Time ( $t_L$ ) maintained above $T_L$		60-150 seconds	60-150 seconds
Peak package body temperature ( $T_p$ )		See Table 5-2	See Table 5-3
Time within 5°C of actual Peak Temperature ( $t_p$ ) <sup>2</sup>		10-30 seconds	20-40 seconds
Ramp-down rate ( $T_p$ to $T_L$ )		6°C/second max	6°C/second max
Time 25°C to peak temperature		6 minutes max	8 minutes max

Note 1: All temperatures refer to topside of the package, measured on the package body surface.

Note 2: Time within 5°C of actual peak temperature ( $t_p$ ) specified for the reflow profiles is a “supplier” minimum and “user” maximum.

### SnPb - Classification Temperature

Table 6-2

Package Thickness	Volume $mm^3$ < 350	Volume $mm^3$ $\geq 350$
<2.5 mm	240 +0/-5°C	225 +0/-5°C
$\geq 2.5$ mm	225 +0/-5°C	225 +0/-5°C

**Pb-free - Classification Temperature Table 6-3**

Package Thickness	Volume mm <sup>3</sup> < 350	Volume mm <sup>3</sup> 350 - 2000	Volume mm <sup>3</sup> > 2000
< 1.6mm	260°C	260°C	260°C
1.6 mm - 2.5mm	260°C	250°C	245°C
> 2.5mm	250°C	245°C	245°C

\*Tolerance: The device manufacturer/supplier shall assure process compatibility up to and including the stated classification temperature (this means Peak reflow temperature +0°C. For example 260°C+0°C) at the rated MSL level.

## 7. Revision History

Date	Revision	Description
2023.06.29	V1.0	Initial Release
2023.07.31	V1.1	Update resource description
2023.09.16	V1.2	Update Features
2023.10.13	V1.3	Add IC Marking Information Update Absolute Maximum Ratings Update IO Input/Output Electrical Logical Characteristics Update BT_Features
2023.10.24	V1.4	Update Block Diagram
2023.11.03	V1.5	Update BT_Features Update IC Marking Information