

# **AC6328B Datasheet**

**Zhuhai Jieli Technology Co.,LTD**

**Version: V1.0**

**Date: 2021.05.19**

**Copyright © Zhuhai Jieli Technology Co.,LTD. All rights reserved.**

## AC6328B Features

### High performance 32-bit RISC CPU

- RISC 32-bit CPU
- DC-96MHz operation
- 73KB data RAM
- 8KB I-cache 2way
- 1KB Rocache 1way
- 64 Vectored interrupts
- 8 Levels interrupt priority

### Flexible I/O

- 2 GPIO pins
- All GPIO pins can be programmable as input or output individually
- All GPIO pins are internal pull-up/pull-down selectable individually
- CMOS/TTL level schmitt triggered input
- External wake up/interrupt on all GPIOs

### Peripheral Feature

- One Full Speed USB OTG controller
- One full-duplex advanced UART(DMA)
- One IIC interface supports host and device mode
- 2 channels 10-bit ADC
- 1 channel 8 levels Low Power Detector
- Embedded PMU support low power mode
- Watchdog
- Power-on reset

### Bluetooth Feature

- CMOS single-chip fully-integrated radio and baseband
- Compliant with Bluetooth
- V5.0+BR+EDR+BLE specification
- Bluetooth Piconet and Scatternet support
- Meet class2 and class3 transmitting power requirement
- Support GFSK and  $\pi/4$  DQPSK all packet types
- Provides +8dbm transmitting power
- Receiver with -92dBm sensitivity
- Support  
a2dp\avctp\avdtp\avrcp\hfp\spp\smp\att\gap\gatt\rfcomm\sdp\l2cap profile

### Power Supply

- VBAT is 1.8V to 5.5V
- VDDIO is 1.8V to 3.4V

### Packages

- SOP8

### Temperature

- Operating temperature: -40°C to +85°C
- Storage temperature: -65°C to +150°C

### Confidential

The information contained herein is the exclusive property of JIELI and shall not be distributed, reproduced, or disclosed in whole or in part without prior written permission of JIELI.

# 1. Block Diagram

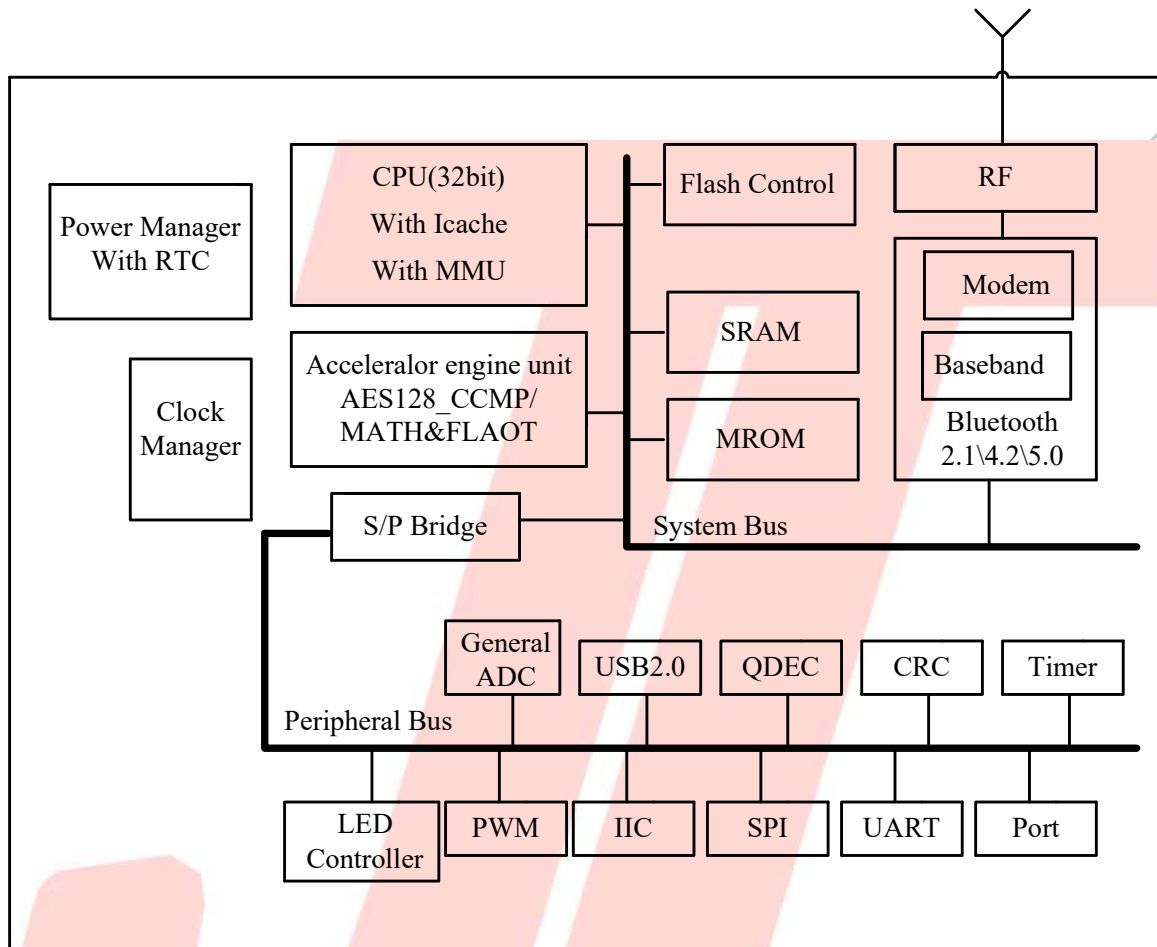

Figure 1-1 AC6328B\_SOP8 Block Diagram

## 2. Pin Definition

### 2.1 Pin Assignment

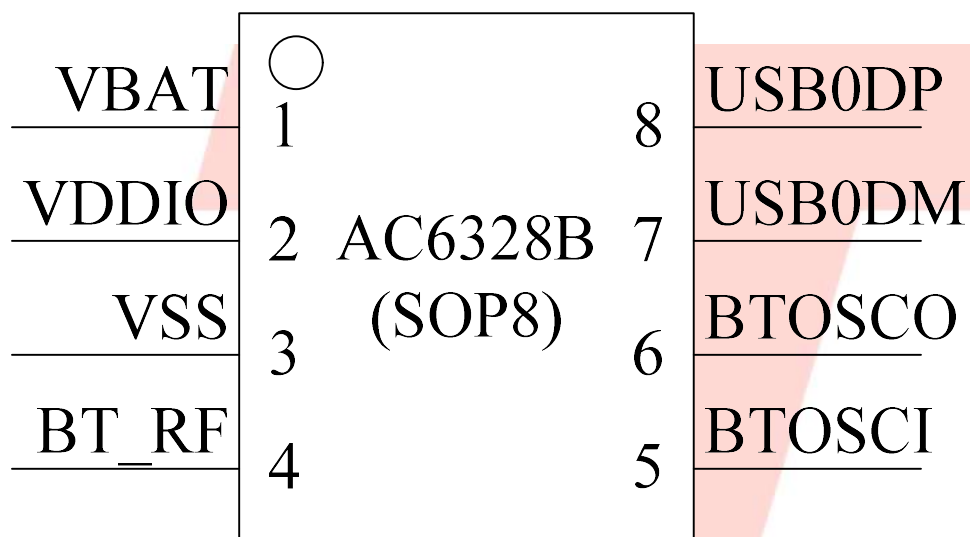

Figure 2-1 AC6328B\_SOP8 Package Diagram

## 2.2 Pin Description

Table 2-1 AC6328B\_SOP8 Pin Description

PIN NO.	Name	I/O Type	Function	Other Function
1	VBAT	P	LDO Power	-
2	VDDIO	P	IO Power 3.3V	-
3	VSS	P	GND	-
4	BT_RF	-	RF Antenna	-
5	BTOSCI	I	BTOSCI	-
6	BTOSCO	O	BTOSCO	-
7	USB0DM	I/O	GPIO (pull down)	IIC_SDA_A: IIC SDA(A); ADC11: ADC Channel 11; UART1_RXD: Uart1 Data In(D);
8	USB0DP	I/O	GPIO (pull down)	IIC_SCL_A: IIC SCL(A); ADC10: ADC Channel 10; UART1_TXD: Uart1 Data Out(D);

### Confidential

The information contained herein is the exclusive property of JIELI and shall not be distributed, reproduced, or disclosed in whole or in part without prior written permission of JIELI.

## 3. Electrical Characteristics

### 3.1 Absolute Maximum Ratings

Table 3-1

Symbol	Parameter	Min	Max	Unit
T <sub>opt</sub>	Operating temperature	-40	+85	°C
T <sub>stg</sub>	Storage temperature	-65	+150	°C
V <sub>BAT</sub>	Supply Voltage	-0.3	5.5	V
V <sub>VDDIO</sub>	3.3V IO Input Voltage	-0.3	3.6	V

Note : The chip can be damaged by any stress in excess of the absolute maximum ratings listed below

### 3.2 Recommended Operating Conditions

Table 3-2

Symbol	Parameter	Min	Typ	Max	Unit	Test Conditions
V <sub>BAT</sub>	Voltage Input	1.8	3.7	5.5	V	–
V <sub>VDDIO</sub>	Voltage Input	-	3.0	-	V	–
I <sub>VDDIO</sub>	Loading current	-	-	60	mA	V <sub>BAT</sub> = 4.2V

### 3.3 IO Input/Output Electrical Logical Characteristics

Table 3-3

IO input characteristics						
Symbol	Parameter	Min	Typ	Max	Unit	Test Conditions
V <sub>IL</sub>	Low-Level Input Voltage	-0.3	–	0.3* V <sub>VDDIO</sub>	V	V <sub>VDDIO</sub> = 3.3V
V <sub>IH</sub>	High-Level Input Voltage	0.7* V <sub>VDDIO</sub>	–	V <sub>VDDIO</sub> +0.3	V	V <sub>VDDIO</sub> = 3.3V
IO output characteristics						
V <sub>OL</sub>	Low-Level Output Voltage	–	–	0.33	V	V <sub>VDDIO</sub> = 3.3V
V <sub>OH</sub>	High-Level Output Voltage	2.7	–	–	V	V <sub>VDDIO</sub> = 3.3V

#### Confidential

The information contained herein is the exclusive property of JIELI and shall not be distributed, reproduced, or disclosed in whole or in part without prior written permission of JIELI.

### 3.4 Internal Resistor Characteristics

Table 3-4

Port	Drive Strength	Internal Pull-Up Resistor	Internal Pull-Down Resistor	Comment
USB0DP	4mA	1.5K	15K	1. USB0DM&USB0DP default pull down 2. Internal pull-up/pull-down resistance   accuracy $\pm 20\%$
USB0DM	4mA	180K	15K	

### 3.5 BT Characteristics

#### 3.5.1 Transmitter

##### Basic Data Rate

Table 3-5

Parameter	Min	Typ	Max	Unit	Test Conditions
RF Transmit Power		4	6	dBm	25°C, Power Supply VDDIO=3.3V 2441MHz
RF Power Control Range		20		dB	
20dB Bandwidth		950		KHz	
Adjacent Channel	+2MHz	-40		dBm	
	-2MHz	-38		dBm	
Transmit Power	+3MHz	-44		dBm	
	-3MHz	-35		dBm	

##### Enhanced Data Rate

Table 3-6

Parameter	Min	Typ	Max	Unit	Test Conditions
Relative Power		-1		dB	25°C, Power Supply VDDIO=3.3V 2441MHz
$\pi/4$ DQPSK Modulation Accuracy	DEVm RMS	6		%	
	DEVm 99%	10		%	
	DEVm Peak	15		%	
Adjacent Channel	+2MHz	-40		dBm	
	-2MHz	-38		dBm	
Transmit Power	+3MHz	-44		dBm	
	-3MHz	-35		dBm	

#### 3.5.2 Receiver

##### Basic Data Rate

Table 3-7

Parameter	Min	Typ	Max	Unit	Test Conditions
-----------	-----	-----	-----	------	-----------------

#### Confidential

The information contained herein is the exclusive property of JIELI and shall not be distributed, reproduced, or disclosed in whole or in part without prior written permission of JIELI.

Sensitivity			-92		dBm	25°C, Power Supply VDDIO=3.3V 2441MHz
Co-channel Interference Rejection			-13		dB	
Adjacent Channel	+1MHz		+5		dB	
	-1MHz		+2		dB	
	+2MHz		+37		dB	
Interference Rejection	-2MHz		+36		dB	
	+3MHz		+40		dB	
	-3MHz		+35		dB	

**Enhanced Data Rate** **Table 3-8**

Parameter		Min	Typ	Max	Unit	Test Conditions
Sensitivity			-92		dBm	25°C, Power Supply VDDIO=3.3V 2441MHz
Co-channel Interference Rejection			-13		dB	
Adjacent Channel	+1MHz		+5		dB	
	-1MHz		+2		dB	
	+2MHz		+37		dB	
Interference Rejection	-2MHz		+36		dB	
	+3MHz		+40		dB	
	-3MHz		+35		dB	

**Confidential**

The information contained herein is the exclusive property of JIELI and shall not be distributed, reproduced, or disclosed in whole or in part without prior written permission of JIELI.



## 4. Package Information

### 4.1 SOP8

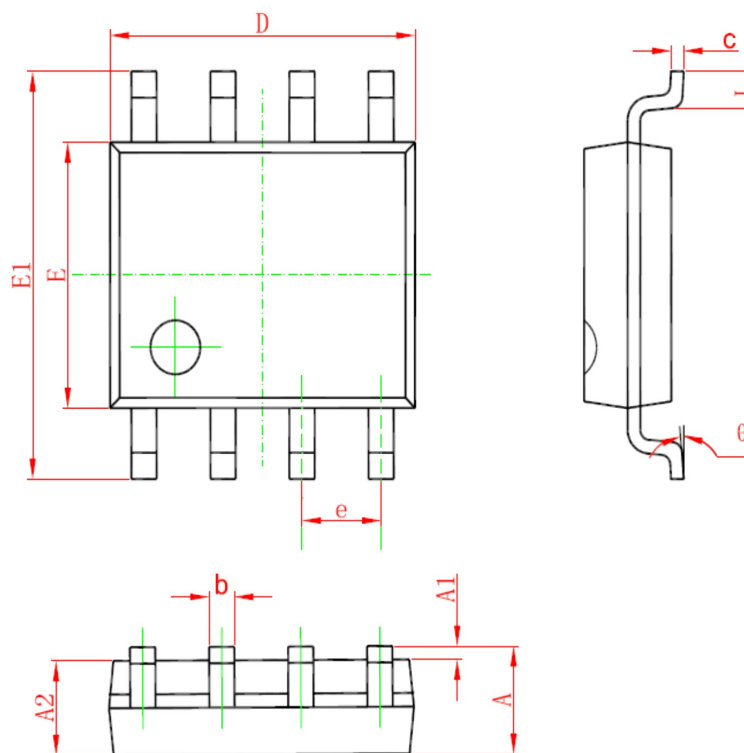

Symbol	Dimension In Millimeters		Dimension In Inches	
	Min	Max	Min	Max
A	1.350	1.750	0.053	0.069
A1	0.100	0.250	0.004	0.010
A2	1.350	1.550	0.053	0.061
b	0.330	0.510	0.013	0.020
c	0.170	0.250	0.007	0.010
D	4.700	5.100	0.185	0.201
E	3.800	4.000	0.150	0.157
E1	5.800	6.200	0.228	0.244
e	1.27TYP		0.050TYP	
L	0.400	1.270	0.016	0.050
$\theta$	$0^{\circ}$	$8^{\circ}$	$0^{\circ}$	$8^{\circ}$

Figure 4-1 AC6328B\_SOP8 Package

## 5. Package Type Specification

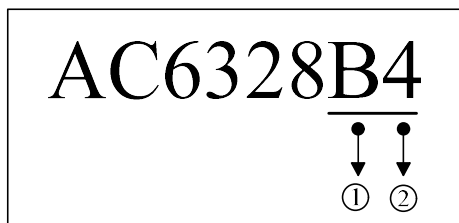

① Represents different packages

② Represents different memory sizes

2: 2Mbit Flash

4: 4Mbit Flash

## 6. Revision History

Date	Revision	Description
2021.05.19	V1.0	Initial Release